

187 - GR VIVACCE SOLTEIRO

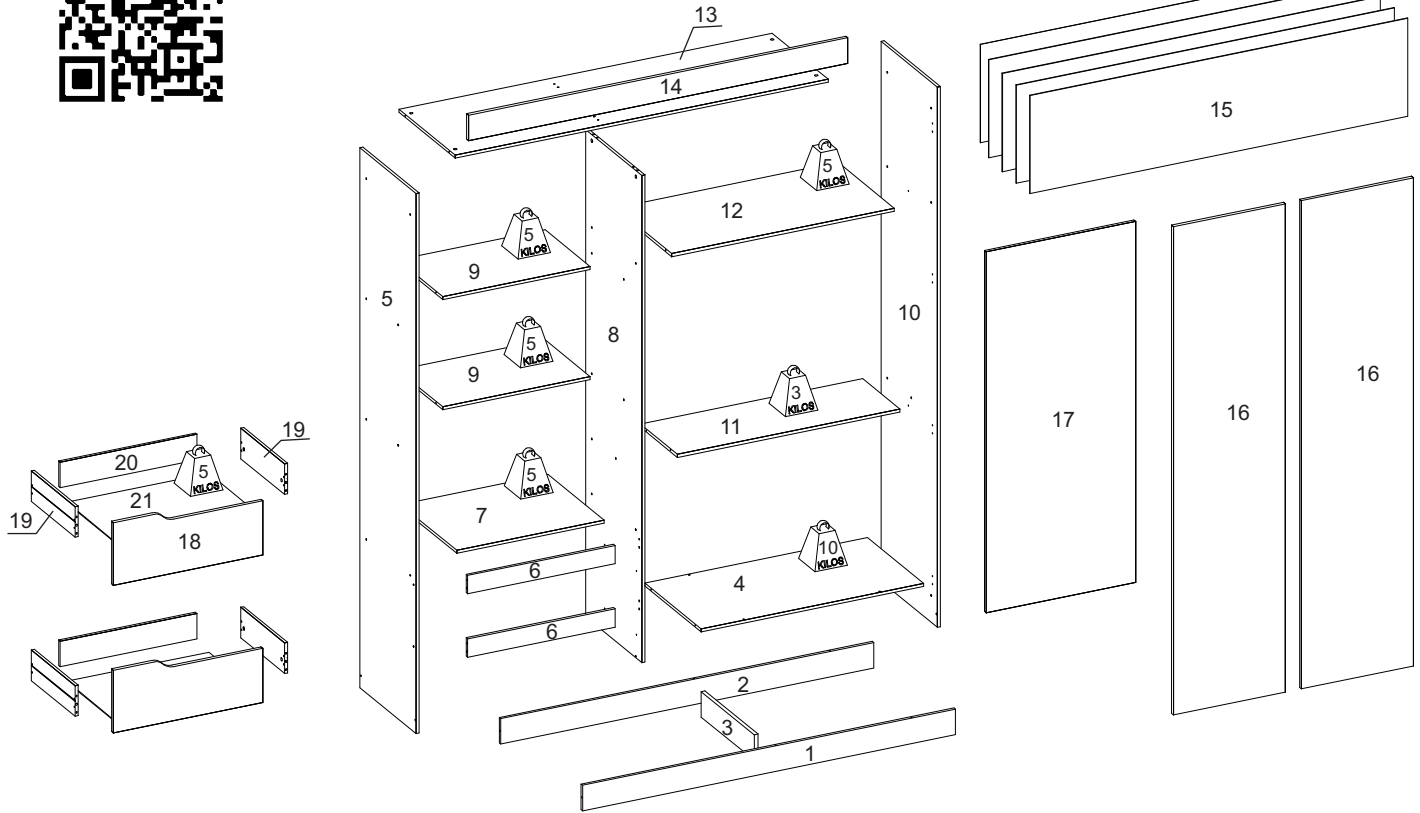

LISTA DE PEÇAS / PIECES LIST / LISTA DE PIEZAS

SEQ.	REF.	DESCRIÇÃO	DESCRIPTION	DESCRIPCIÓN	MAT.PRIMA	COMP.	LARG.	ESP.	QTD.
1	331733	Rodapé frontal	Front footer	Pie de página frontal	MDP	1493	100	12	1
2	331734	Rodapé traseiro	Back footer	Pie de página posterior	MDP	1493	100	12	1
3	331735	Trava rodapé	Footer lock	Bloqueo de pie de página	MDP	424	100	15	1
4	331736	Base	Base	Base	MDP	891	450	12	1
5	331737	Lateral esquerda	Left side	Lado izquierdo	MDP	2120	450	12	1
6	331738	Vista gaveta	Drawer view	Vista del cajón	MDP	590	72	12	2
7	331739	Tampo gaveteiro	Drawer top	Tapa del cajón	MDP	590	450	12	1
8	331740	Divisória esquerda	Left divider	divisor izquierdo	MDP	1912	450	12	1
9	331741	Prateleira	Shelf	Estante	MDP	590	360	12	2
10	331742	Lateral direita	Right side	Lado derecho	MDP	2120	450	12	1
11	331743	Prateleira inferior	Bottom shelf	estante inferior	MDP	891	298	12	1
12	331744	Prateleira superior	Top shelf	estante superior	MDP	891	450	12	1
13	331745	Chapéu	Hat	Sombrero	MDP	1493	450	12	1
14	331746	Vista	View	Vista	MDP	1517	100	15	1
15	331747	Fundo	Bottom	Abajo	HDF	1513	385	3	5
16	331748	Porta central	Central door	puerta central	MDP	1916	448	15	2
17	331749	Porta	Door	Puerta	MDP	1416	598	15	1
18	331750	Frente de gaveta esquerda	Left drawer front	Frente del cajón izquierdo	MDP	598	246	15	2
19	331751	Lateral de gaveta	Drawer side	Lado del cajón	MDP	350	120	12	4
20	331752	Contra fundo	Against background	Contra el fondo	MDP	546	100	12	2
21	331753	Fundo da gaveta	Drawer bottom	Fondo del cajón	HDF	569	355	3	2

INSTRUÇÃO MONTAGEM PRODUTO
Instructions to Assembly / Instrucciones de montaje

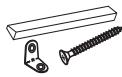

Separe as peças e acessórios de maneira organizada
Separate parts and accessories in way organized
Separe las piezas y accesorios de manera organizada

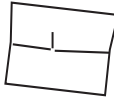

Forrar o chão com o papelão das embalagens.
Cover the floor with the cardboard
Cubra el suelo con la embalaje de cartón



É necessário 01 pessoa para montar o produto
01 people are required to assemble the product
Se requieren 0 persona para ensamblar el producto

O produto deve ser a montado por um profissional qualificado
The product must be assembly by a professional
El producto debe ser ensamblado por un profesional calificado

Ferramentas necessárias
(não fornecidas)

Not include tools / No herramientas



CUIDADO PARA CONSERVAÇÃO E LIMPEZA DO MÓVEL
Care to conservation and clean / Cuidados de limpieza

Peso máximo de carga informado refere-se a objetos distribuído de maneira uniforme sobre toda área de contato da peça



The maximum load weight informed refers to objects distributed evenly over the entire contact area of the part
Conjunto de carga máxima de peso se refere a objetos distribuídos uniformemente sobre toda el área de contacto de la pieza de trabajo.



Não molhar o móvel e não expor em lugar úmido
Do not wet the mobile and do not expose in a wet place
No moje el producto y no exponer en un lugar húmedo



Não expor o móvel próximo de fontes de calor.
Do not expose the mobile near heat sources
no exponga cercano de fuentes de calor



Não usar produtos abrasivos.
Do not use abrasive products.
No utilice productos abrasivos.



Limpe com flanela limpa e seca.
Clean with dry cloth
Limpieza con un paño limpio y seco

LISTA DE ACESSÓRIOS E FERRAGENS / ACCESSORIES AND HARDWARE / ACCESORIOS Y HARDWARE



A - 700137- Parafuso 4,5x45 (40x)
screw / tornillo



B - 700124-Parafuso 3,5x25 (17x)
screw / tornillo



C - 700121-Parafuso 3,5x12 (78x)
screw / tornillo



D- 700157-Prego (117x)
nail / clavo



E - 700490 - Kit com 6 Pes (01x)
foot / pie



F- 700542-Cavilha 6x30 (14x)
peg / cerrojo



G- 700146-Parafuso minifix (06x)
Minifix screw /
Tornillo minifix



H- 700148-Tambor Minifix (06x)
Minifix Drum / Tambor minifix



I - 702024-Corrediça (02x)
runners / corredera



J - 700539-Cantoneira (07x)
corner / esquina



K - 700127-Parafuso 4,0x12 (44x)
screw / tornillo



L- 700446 - Porca cilíndrica (04x)
Cylindrical Nut / Tuerca cilíndrica



M - 700438 - Suporte cabide (04x)
hook support / soporte gancho



N - 701281 - Cabideiro Alumínio (02x)
Coat Rack / Perchero



O- 700395 - Dobradiça (11x)
700390 - Calço (11x)
hinge / bisagra



P- 702105-Puxador 600 mm (03x)
Handle / Manija



Q- 702164-Perfil H (04x)
Frame / Perfil



R- 700516 - Cola (01x)
glue / pegamento



S- 700419-Tapa furo (37x)
cover / tapa

01° PASSO - Fixar as peças 1 e 2 na peça 4

01° STEP - Fix parts 1 and 2 to part 4

01° PASO - Fije las partes 1 y 2 a la parte 4

A

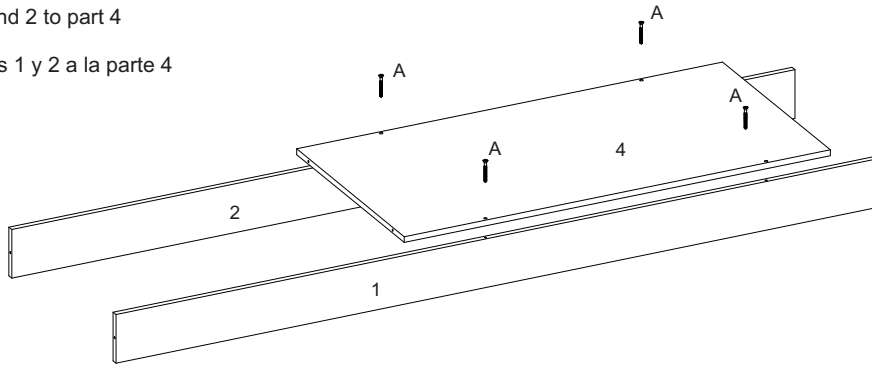

02° PASSO - Fixar a peça 3 nas peças 1 e 2, fixar os acessórios E nas peças 1, 2 e 3

02° STEP - Attach part 3 to pieces 1 and 2, attach accessories E to pieces 1, 2 and 3

02° PASO - Fije la pieza 3 a las piezas 1 y 2, fije los accesorios E a las piezas 1, 2 y 3

C



E



J

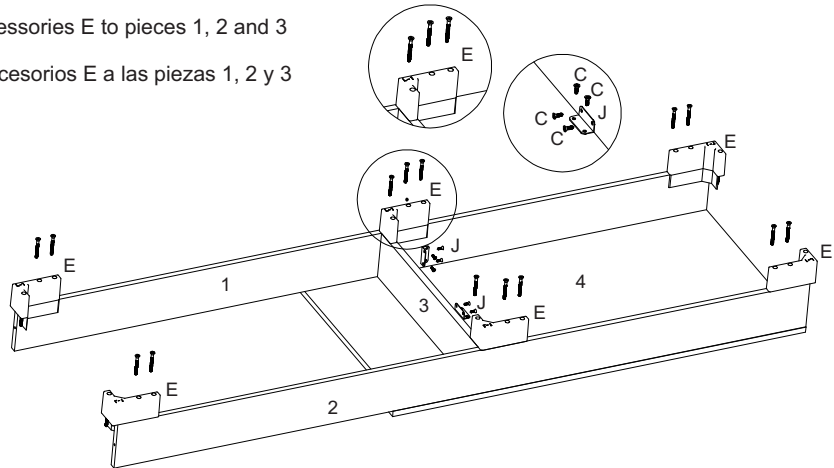

03° PASSO - Fixar os acessórios I nas peças 5 e 8

03° STEP - Attach accessories I to parts 5 and 8

03° PASO - Conecte los accesorios I a las partes 5 y 8.

C



I

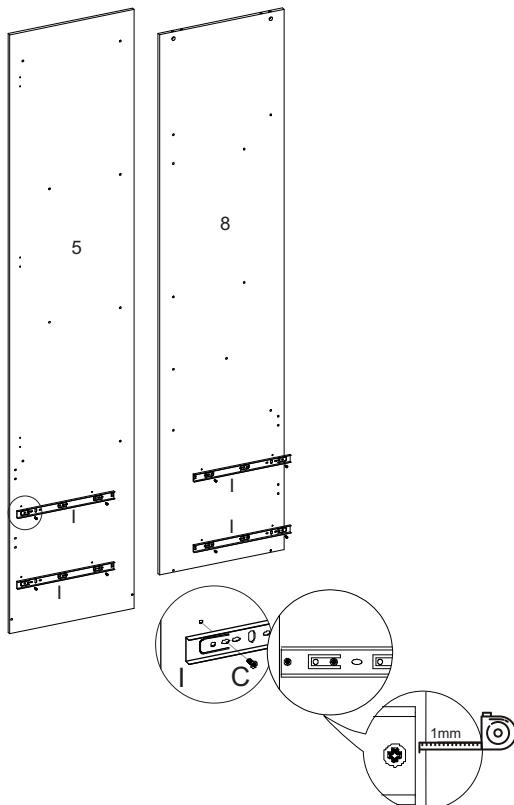

04° PASSO - Fixar a peça 5 nas peças 1 e 2

04° STEP - Fix part 5 on parts 1 and 2

04° PASO - Fijar la parte 5 en las partes 1 y 2

A

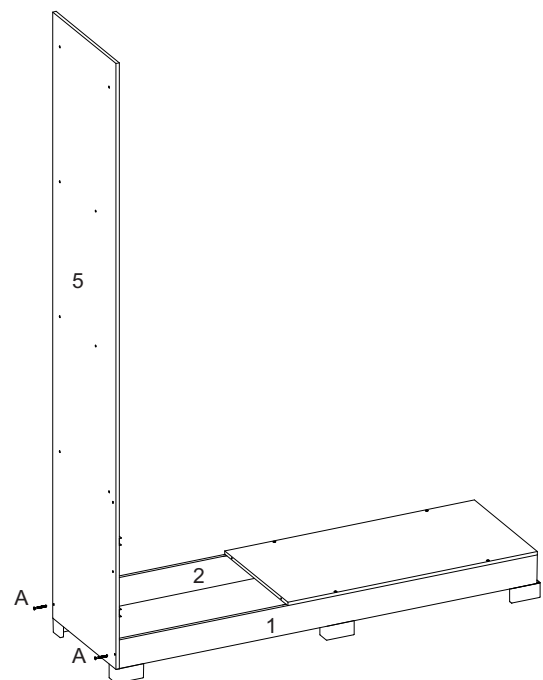

05° PASSO - Fixa a peça 6 na peça 5

05° STEP - Fix part 6 to part 5

05° PASO - Fije la parte 6 a la parte 5

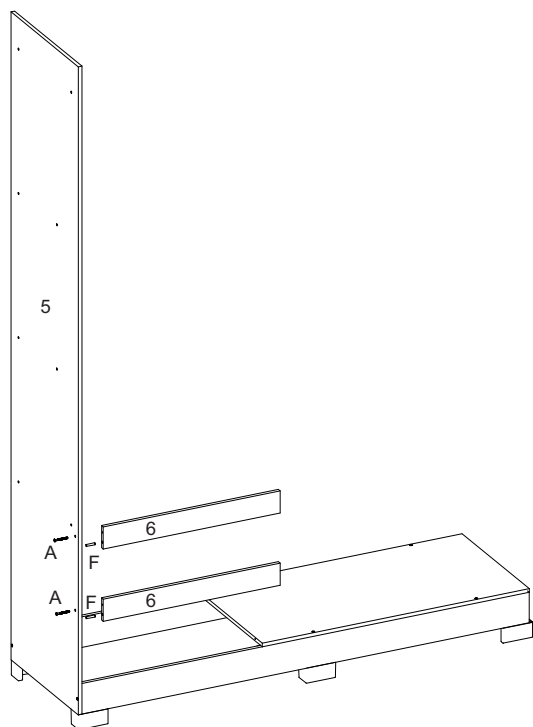
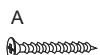

06° PASSO - Fixar a peça 6 na peça 8, Fixar a peça 7 nas peças 5 e 8

06° STEP - Fix part 6 to part 8, Fix part 7 to parts 5 and 8

06° PASO - Fije la parte 6 a la parte 8, Fije la parte 7 a las partes 5 y 8

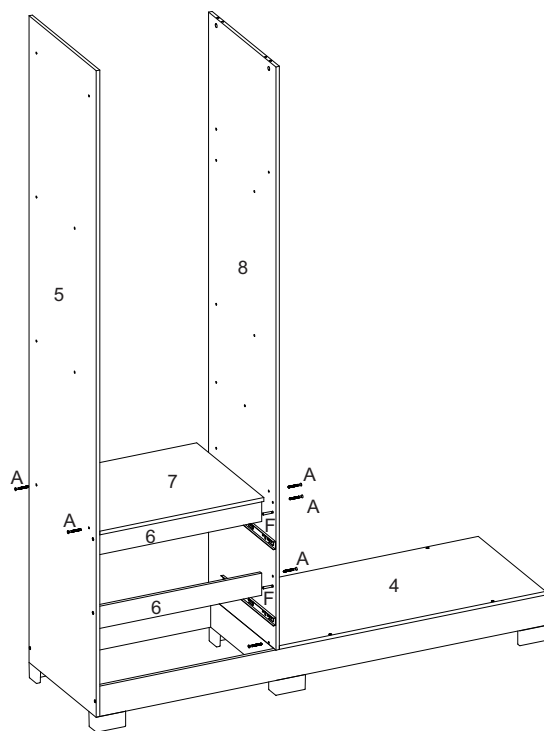

07° PASSO - Fixar as peças 9 nas peças 5 e 8

07° STEP - Fix parts 9 to parts 5 and 8

07° PASO - Fije las partes 9 a las partes 5 y 8

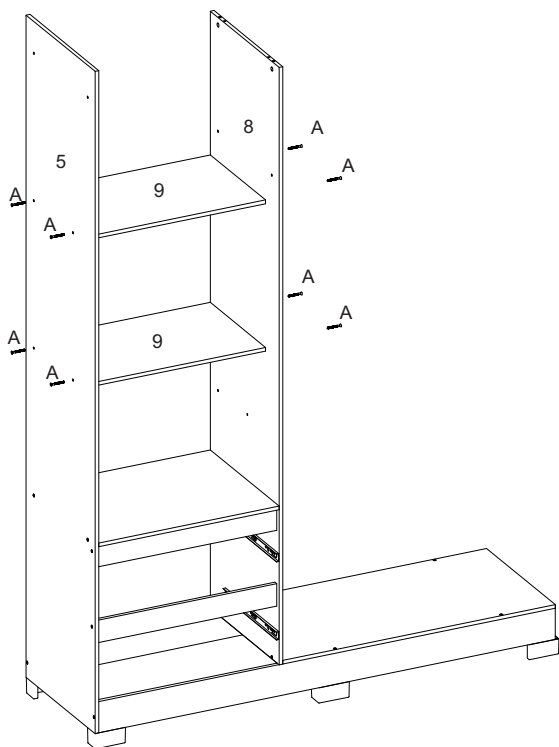

08° PASSO - Fixar a peça 10 nas peças 1,2 e 4

08° STEP - Attach piece 10 to pieces 1,2 and 4

08° PASO - Une la pieza 10 a las piezas 1,2 y 4.

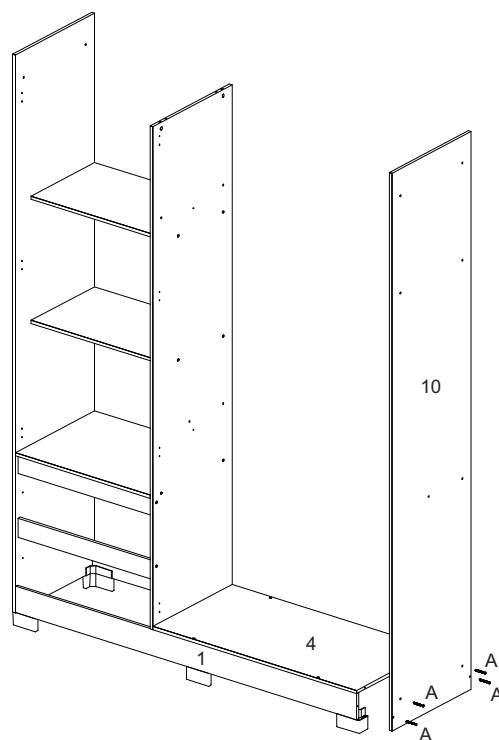

09º PASSO - Fixar as peças 11 e 12 nas peças 8 e 10

09º STEP - Attach pieces 11 and 12 to pieces 8 and 10

09º PASO - Une las piezas 11 y 12 a las piezas 8 y 10.

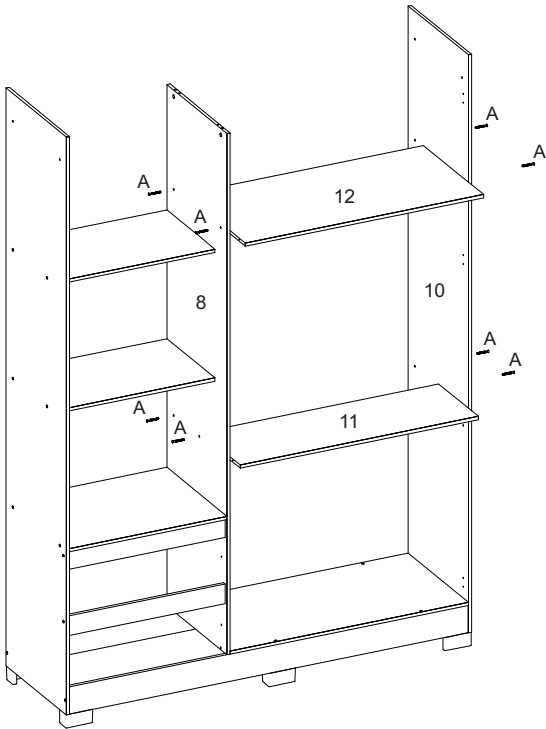

10º PASSO - Fixar a peça 13 nas peças 5, 8 e 10

10º STEP - Attach piece 13 to pieces 5, 8 and 10

10º PASO - Une la pieza 13 a las piezas 5, 8 y 10.

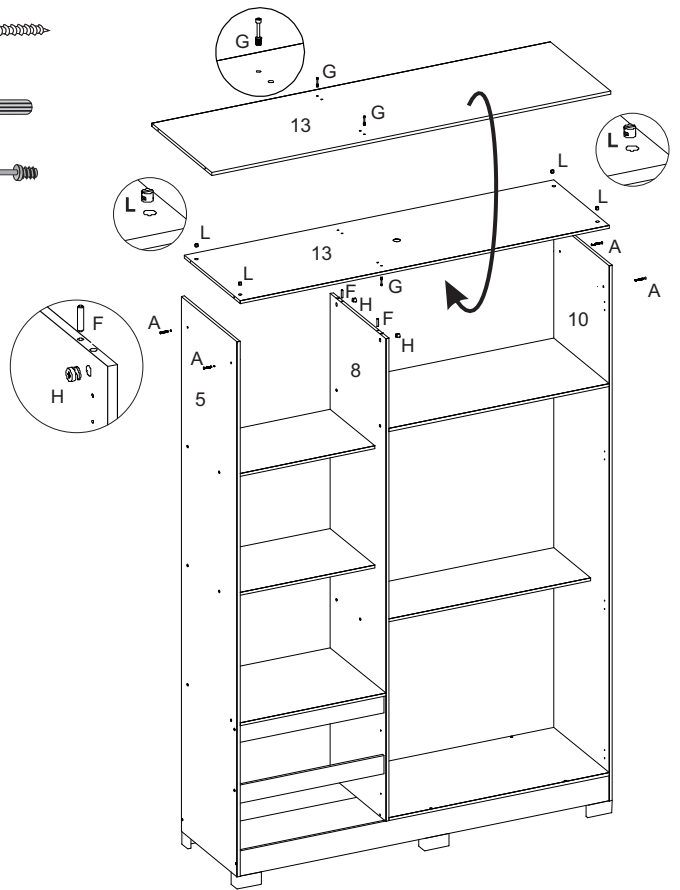
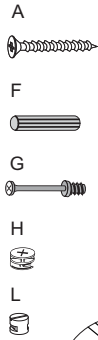

11º PASSO - Fixar a peça 10 nas peças 5, 10 e 13

11º STEP - Attach piece 10 to pieces 5, 10 and 13

11º PASO - Une la pieza 10 a las piezas 5, 10 y 13.

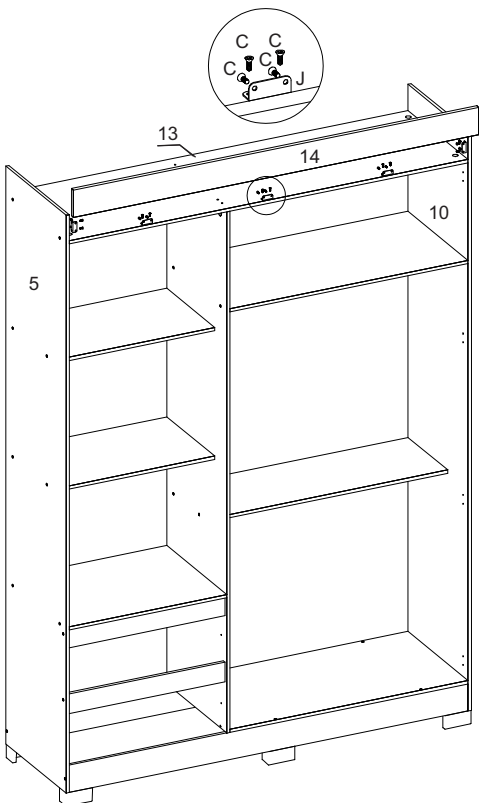

12º PASSO - Fixar as peças 15 utilizando os acessórios C, D e Q

12º STEP - Fix parts 15 using accessories C, D and Q

12º PASO - Fijar las piezas 15 utilizando los accesorios C, D y Q.

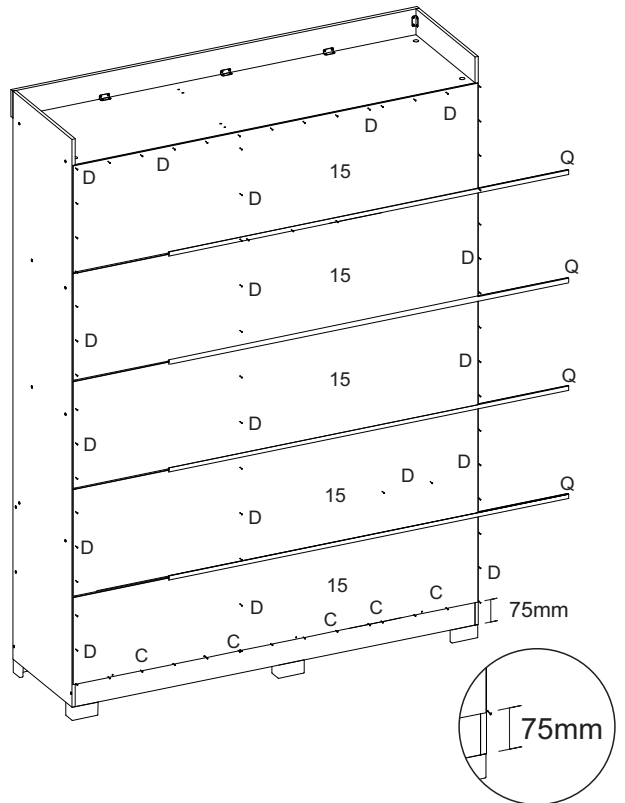
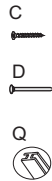

13º PASSO - Fixar o acessório M nas peças 8 e 10

13º STEP - Attach accessory M to parts 8 and 10

13º PASO - Conecte el accesorio M a las piezas 8 y 10.

C



M

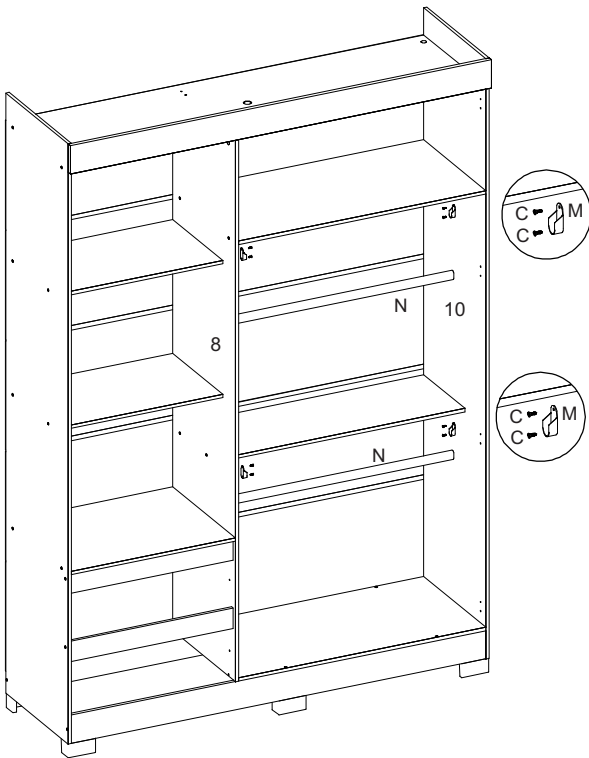

14º PASSO - Fixar as peças 16 e 17 utilizando os acessórios O e K
Fixar o acessório V nas peças 16 e 17

14º STEP - Fix parts 16 and 17 using accessories O and K
Attach accessory V to parts 16 and 17

14º PASO - Fijar las piezas 16 y 17 utilizando los accesorios O y K.
Conecte el accesorio V a las piezas 16 y 17.

K



B



V

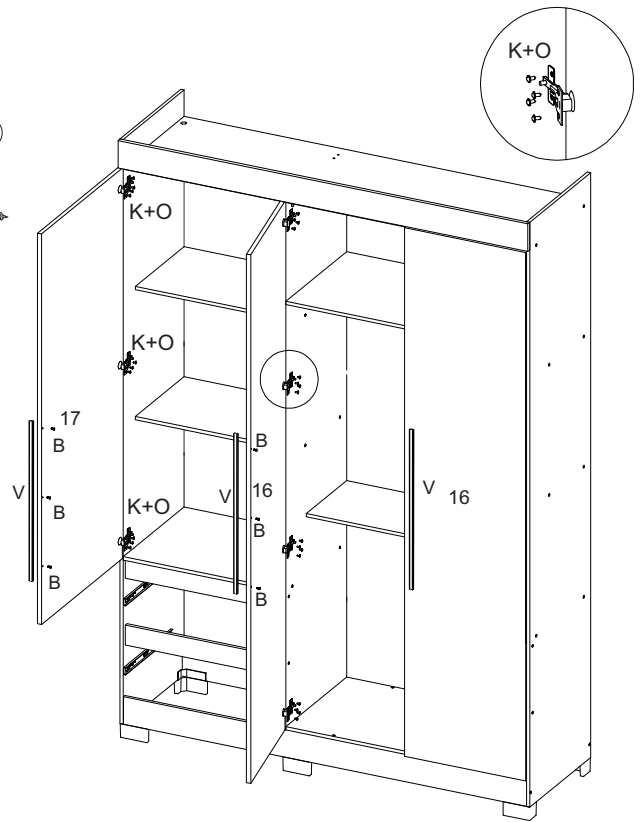

16º PASSO - Fixar as peças 19 nas peças 18 e 20

16º STEP - Attach pieces 19 to pieces 18 and 20

16º PASO - Une las piezas 19 a las piezas 18 y 20.

B

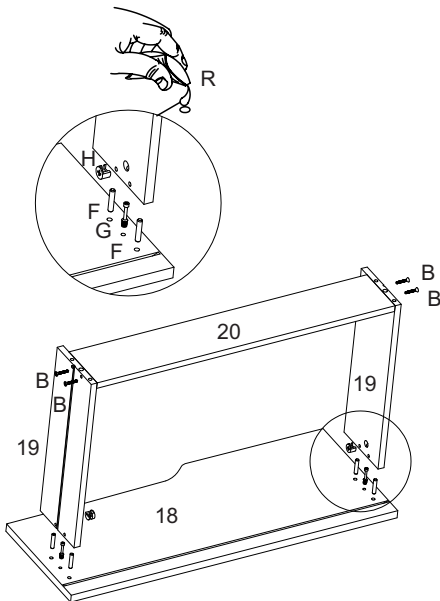

17º PASSO - Fixar a peça 21 nas peça 19 e 20

17º STEP - Attach piece 21 to pieces 19 and 20

17º PASO - Une la pieza 21 a las piezas 19 y 20.

C



D

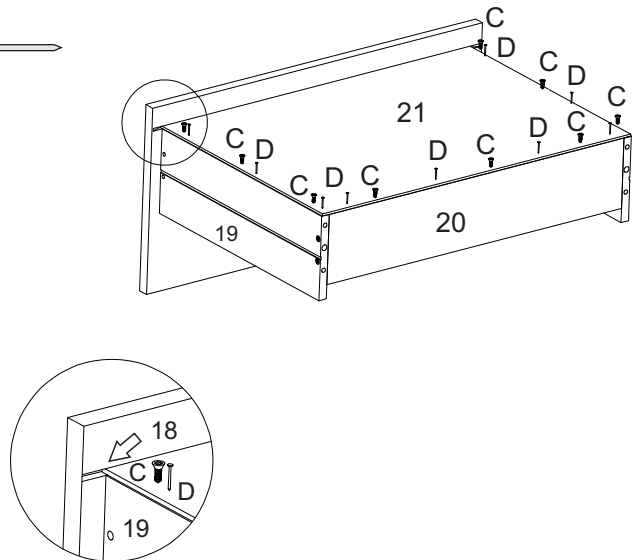

18° PASSO - Fixar o acessório I nas 19

18° STEP - Attach accessory I to the 19

18° PASO - Adjunte el accesorio I al 19

C

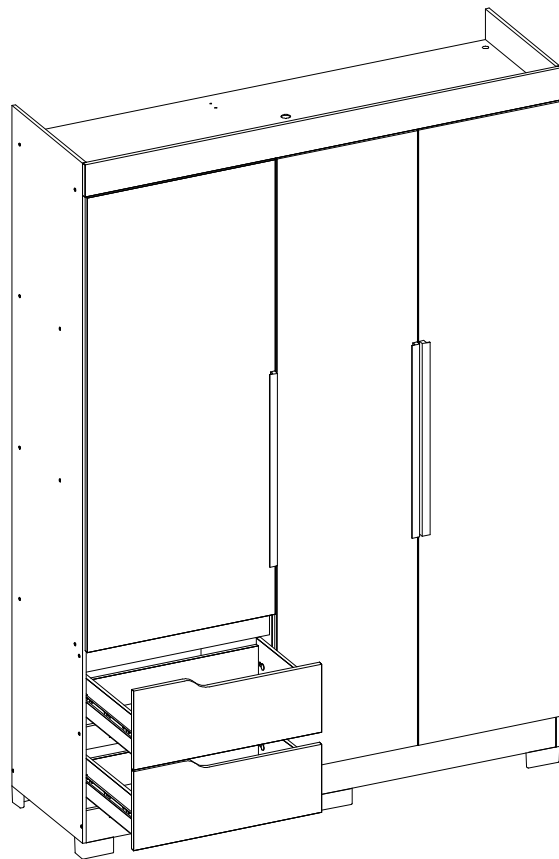
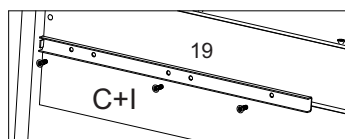
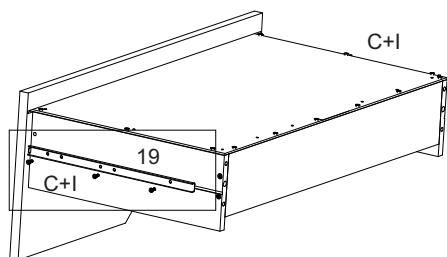
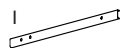
Aspecto final do produto
Aspecto final del producto.
Final appearance of the product

MONTAGEM PARA O PRODUTO QUE CONTEM ESPELHO
ASSEMBLY FOR THE PRODUCT THAT CONTAINS MIRROR
MONTAJE DEL PRODUCTO QUE CONTIENE ESPEJO

